



CONCEPTRONIC

User Manual

# Wireless Pan & Tilt Camera

CIPCAMPTIWL

v1.0



# Index

<b>1</b>	<b>INTRODUCTION.....</b>	<b>4</b>
1.1	THE PACKAGE INCLUDES .....	4
1.2	FUNCTION AND FEATURES .....	4
1.3	TECHNICAL SPECIFICATIONS.....	4
<b>2</b>	<b>APPEARANCE AND INTERFACE.....</b>	<b>6</b>
2.1	APPEARANCE.....	6
2.2	INTERFACE .....	6
<b>3</b>	<b>VISIT THE CAMERA FROM LAN .....</b>	<b>7</b>
3.1	LAN CONNECTION.....	7
3.2	SEARCH AND SET THE IP ADDRESS OF THE CAMERA.....	7
3.3	VISIT IP CAMERA .....	8
3.3.1	<i>Video Play Area</i> .....	8
<b>4</b>	<b>VISIT IP CAMERA FROM WAN.....</b>	<b>10</b>
4.1	WAN CONNECTION .....	10
4.2	PORT FORWARDING .....	11
4.3	DDNS.....	11
4.3.1	<i>Free DDNS Portal</i> .....	11
4.3.2	<i>Third Party DDNS</i> .....	12
<b>5</b>	<b>OTHER SETTINGS.....</b>	<b>12</b>
5.1	NETWORK SETTING.....	12
5.1.1	<i>Basic Network Setting</i> .....	12
5.1.2	<i>WIFI Setting</i> .....	12
5.1.3	<i>ADSL Setting</i> .....	13
5.1.4	<i>UPnP Setting</i> .....	13
5.1.5	<i>DDNS Setting</i> .....	14
5.1.6	<i>MSN Setting</i> .....	14
5.2	ALARM SETTINGS.....	14
5.2.1	<i>Alarm Setting</i> .....	14
5.2.2	<i>Mail Service Setting</i> .....	16
5.2.3	<i>FTP Service Setting</i> .....	17
5.2.4	<i>Alarm Server</i> .....	17
5.3	ADVANCED.....	18
5.3.1	<i>User Setting</i> .....	18
5.3.2	<i>Multi Device Setting</i> .....	18
5.3.3	<i>Other settings</i> .....	19
5.4	MAINTAIN.....	20

---

5.4.1	<i>Device Information</i> .....	20
5.4.2	<i>Time Setting</i> .....	20
5.4.3	<i>Firmware upgrade</i> .....	20
5.4.4	<i>Restore Factory Default</i> .....	20
5.4.5	<i>User browsing Log</i> .....	21
<b>6</b>	<b>CENTRALIZATION CONTROL</b> .....	<b>21</b>
<b>7</b>	<b>FAQ</b> .....	<b>21</b>

# 1 Introduction

The Wireless Pan & Tilt Camera combines a high quality digital video camera with network connectivity and a powerful web server to bring clear video to your desktop from anywhere on your local network or over the Internet.

## 1.1 The package includes

- ✓ Conceptronic Wireless Pan & Tilt Camera
- ✓ Product CD-ROM
- ✓ Network cable
- ✓ Power adapter
- ✓ Replaceable antenna (1x)
- ✓ Multi language quick guide

## 1.2 Function and Features

- ✓ Built-in microphone enables users to monitor the sound on the site. Users can also connect this equipment to a speaker, and it supports two-way intercom function.
- ✓ Pan/tilt function with wide FOV of 270° horizontal and 120° vertical.
- ✓ Easy and convenient to install.
- ✓ Support 802.11b/g protocol, can build up wireless monitoring.
- ✓ Infrared LED for night vision covers 5m area, suitable for 24 hours monitoring.
- ✓ Motion detection and alarm pin can be connected to external sensors to detect environmental situations.
- ✓ Alarm record can be stored by email or FTP server.
- ✓ Support mobile phone viewing.
- ✓ Free DDNS.
- ✓ Free software supporting Multi-view, Long time recording, video replay etc.

## 1.3 Technical Specifications

Item	Sub Item	Description
Image Capture	Sensor	CMOS sensor
	Total of pixel	300k
	Minimum illumination	IR on, 0 Lux
	Lens	f=3.6mm, F=2.0, Fixed Iris
Pan/Tilt	Pan Coverage	270°
	Tilt Coverage	120°

Assistant	Lighting	10pcs 850nm Infrared LEDs, 5m distance
	Lighting Control	Auto control
Video and Audio	Resolution	640*480(VGA)/320*240(QVGA)/160*120(QQVGA)
	Compression	MJPEG
	Frame rate	30fps
	Bit rate	128kbps ~ 5Mbps
	Image Rotation	Mirror /Flip
	Audio Compression	ADPCM
Network	Basic Protocol	TCP/IP、UDP/IP、HTTP、SMTP、FTP、DHCP、DDNS、UPNP、NTP、PPPOE
	Other Protocol	802.11b/g
Other Features	Video control	support
	Dual way audio	support
	Motion Detection	support
	Triggered Actions	Email/FTP/external alarm/send message to alarm server
	User Setting	Three levels
	Date/ Time Setting	support
	Upgrade	Upgrade from network
Hardware Interface	DDNS	Free DDNS
	Ethernet	10Base-T/100base-TX
	Alarm In	1 way
	Alarm Out	1 way
	Audio In	Internal mic
Physical Index	Audio Out	Audio Line-out interface x 1
	Weight	245g
	Main body	100mm(L)*99mm(W)*118mm(H)
	Power	DC 5V
	Power consumption	<6W
	Operating temperature	-20°C ~ 50°C
Software(PC Side)	Operating temperature	10% ~ 80% non-condensing
	OS Supported	Microsoft Windows 98/2000/XP/Vista etc.
	Browser	Internet Explorer6.0 and Above or Compatible Browser, Firefox, Safari etc.
	Application Software	IPCMonitor.exe

## 2 Appearance and Interface

### 2.1 Appearance



Figure 1

Status Indicator: the green light is to show that the device is running  
Slow flicker(one per 2 second): indicates the device is searching for network  
Flicker(one or twice per second: indicates the wired network connected  
Frequent flicker(2~3 times per second): indicates wireless network connected.

### 2.2 Interface

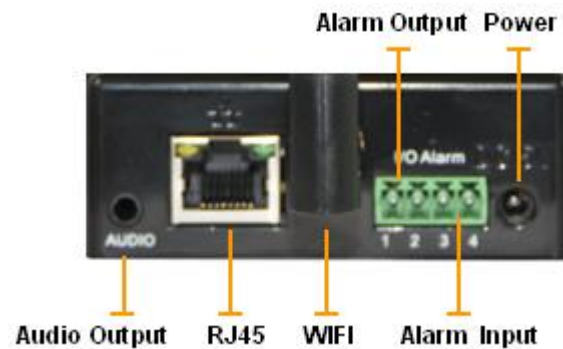

Figure 2

**RESET Button:** Press the RESET button and hold on more than 10 seconds and the camera will restart and restore to factory default settings.

### 3 Visit the Camera from LAN

#### 3.1 LAN connection



Figure 3

#### 3.2 Search and set the IP address of the Camera

Run "BSearch\_en.exe" in the CD, the setting interface as figure 4.

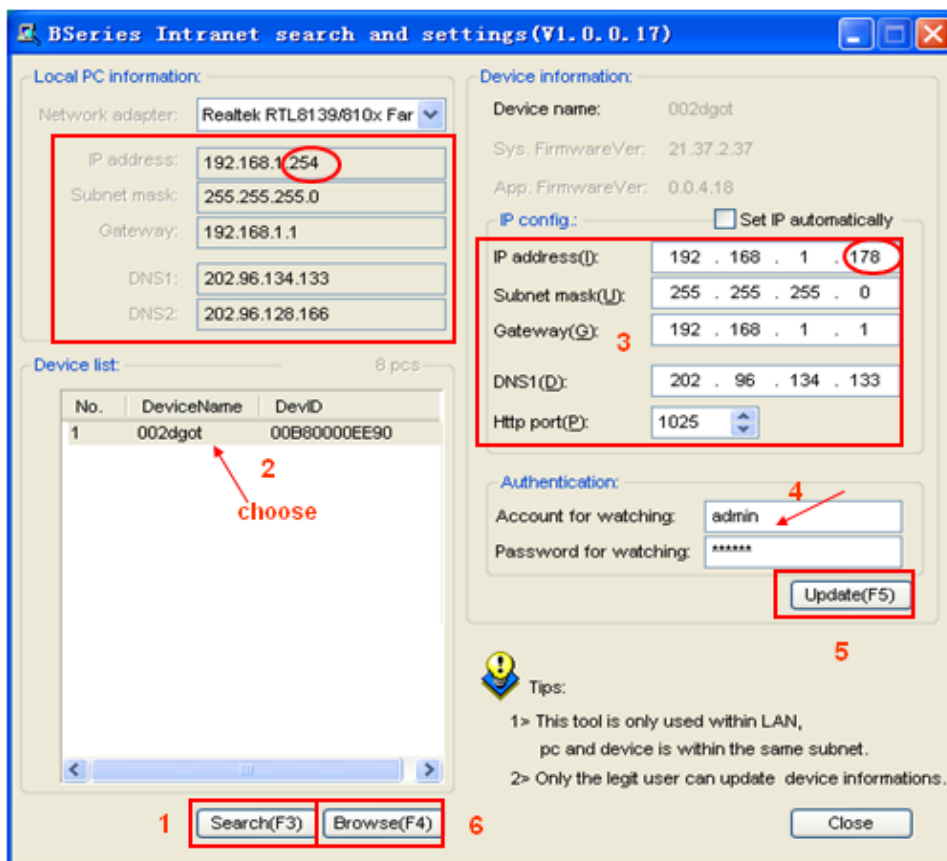

Figure 4

#### Operation Steps:

- 1) Click "Search (F3)
- 2) Choose the device
- 3) Change the IP address of camera according to the information in the red frame on the left. The numbers in the red circle should not be the same.
- 4) Put the user name and password into "Authentication" (**By default, the user name is: admin, password is: 123456**).
- 5) Click "Update"

- 6) After successfully updating, click “Search (F3)”, choose the device and click “Browse (F4)”. Then you may view the camera, like figure 5.

**NOTE:**

- 1) If you don't know how to fill out the content of “IP config”, you could also tick the “Set IP automatically” to get the IP address from the router automatically.
- 2) If you have the firewall software in your PC, when you run the BSearch\_en.exe, it may pop up a window to say “whether you want to block this program or not”, then you should choose not to block.
- 3) The default IP address is 192.168.0.178 and default http port is 80.



Figure 5

### 3.3 Visit IP Camera

We suggest using IE kernel browser to view the video (it can provide more functions), but a Player has to be installed before viewing the video. Click “download and install player” link, it will popup dialogue box as Figure 6, click Run, it will automatically download the player and install.



Figure 6

#### 3.3.1 Video Play Area

After install the plug-ins, click “Mode 1 to view” link in Figure 5 to view the video (video as Figure 7).



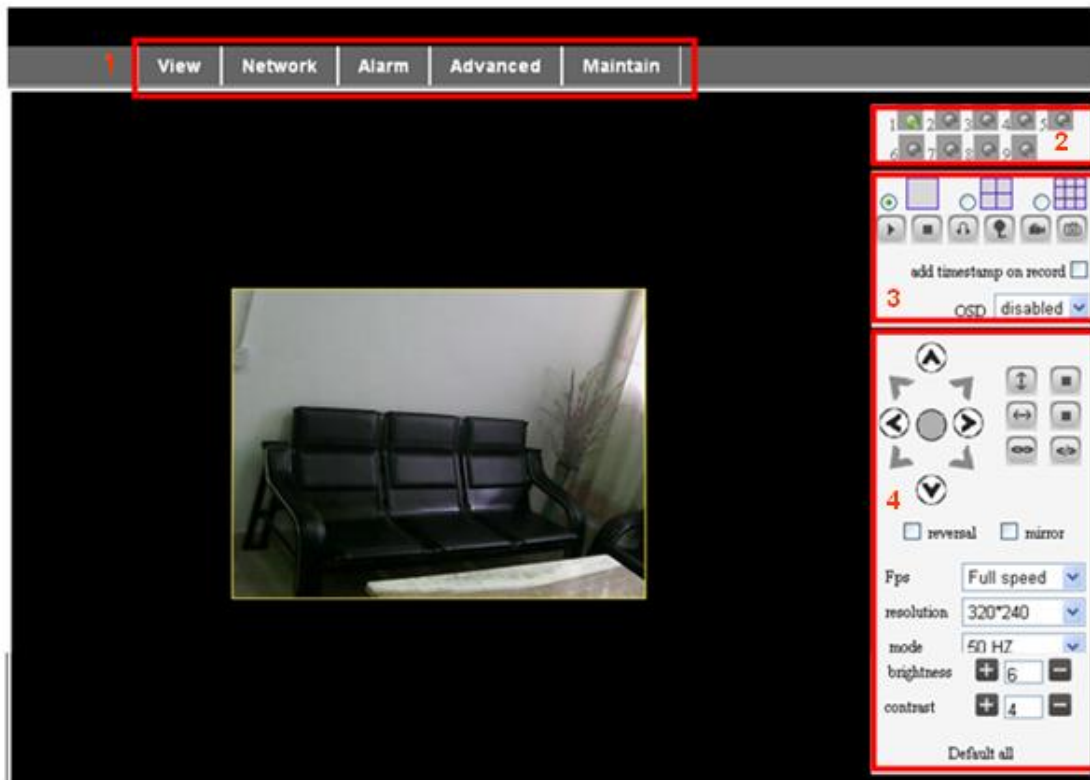

Figure 7

### 1) Main Menu

The main menu includes the function setting of different submenu

### 2) Status Displaying Area

In right up corner, it is the status displaying area, to show the 9 devices' status:

- ◆ if not connected, button is gray
- ◆ if connected, button is green
- ◆ If wrong connected , button is yellow
- ◆ If alarm , button is red

### 3) Multi Channel displaying area

If users add multi channel (refer to 5.3.2) , when shift to 4-Ch, 9-CH, and it will automatically show other devices. You select one device, and you can operate it by these keys: play, stop, and record, control Pan/tilt, etc.



These buttons mean start video, stop, monitor, talk, record and snapshot.

**P.S.:** If you want to click this button  to record the video, please go to advanced—Other Settings to set the Record Path first. Please see figure 8.

Other Settings	
Status LED Mode	Open Indicator LED <input type="button" value="v"/>
<b>PTZ settings</b>	
PTZ Center on Start	No <input type="button" value="v"/>
Horizon Patrol Rounds	1 <input type="button" value="v"/> (NOTE: 0 means infinity)
Vertical Patrol Rounds	1 <input type="button" value="v"/> (NOTE: 0 means infinity)
Manual PTZ Rate	0 <input type="button" value="v"/>
Auto Horizon Rate	5 <input type="button" value="v"/>
Auto Vertical Rate	5 <input type="button" value="v"/>
<b>Path Set</b>	
Record Path	C:\Documents and Settings\All Users\Documents <input type="button" value="Browse.."/>

Figure 8

#### 4) PT and video control

In Pan/Tilt control area, user can control the position according to the arrow sign: up, down, left, right, middle, horizontal cruise, vertical cruise, and stop etc.



Means open IO output and Close IO output.

User can also set the device frame rate, resolution, brightness, contrast and other parameters.

## 4 Visit IP Camera from WAN

### 4.1 Wan connection

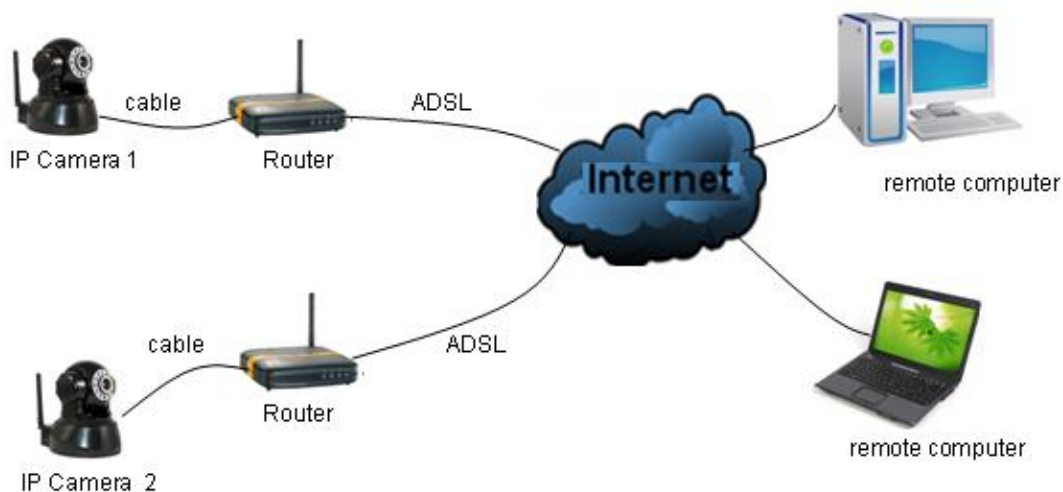

Figure 9

## 4.2 Port forwarding

If visit IP Camera from WAN, you **must** do port forwarding on the router. Take Netgear router for example.

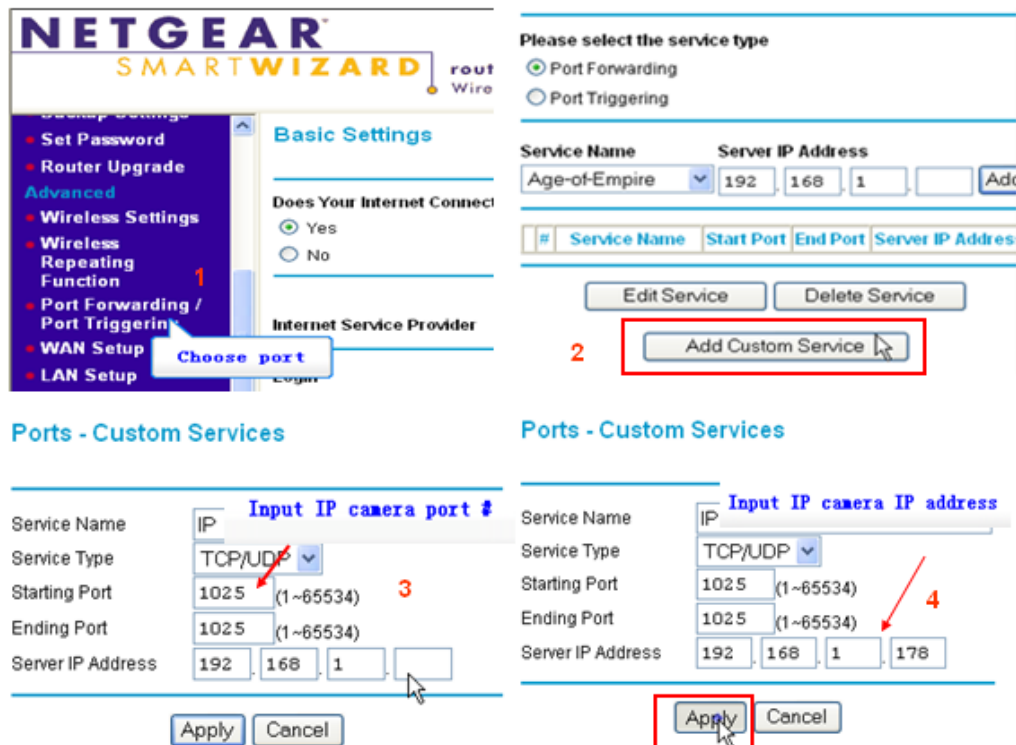

Figure 10

### Operation Steps:

- 1) After login the interface of the router, choose "Port Forwarding"
- 2) Choose "Add custom Service"
- 3) Input IP camera port
- 4) Input IP camera IP address, click "Apply". (the http port and ip address should be the same as figure 4 which set by you own)

**Note: Different router has different settings for port-forwarding; please kindly follow your router guide to do the port-forwarding.**

After the port-forwarding is done, you could view the IP Camera from WAN now.

## 4.3 DDNS

You could also use the manufacturer DDNS to view the device as long as your port-forwarding succeeds.

### 4.3.1 Free DDNS Portal

The Wireless Pan & Tilt Camera has free DDNS service. User can find it in network menu, like figure 11.

Manufacture's DDNS	
Manufacture's Domain	002alcn.nwsvr.com

Figure 11

### 4.3.2 Third Party DDNS

User can also use third part DDNS, such as [www.dyndns.com](http://www.dyndns.com) User must apply a free domain name from this website and fill the info into the below blanks (Figure 12) and save the settings. Then the domain name can be used.

DDNS Service	DynDns.org(dyndns) ▾
DDNS User	btest
DDNS Password	●●●●●●
DDNS Host	btest.dyndns.biz

Figure 12

Note: Using the third party domain name, if the http port is not 80, the port number should be adding to the domain name with colon. Example: <http://btest.dyndns.biz:81>. *N.*

## 5 Other Settings

### 5.1 Network Setting

#### 5.1.1 Basic Network Setting

The user can also enter the Basic Network Settings to set the IP address except using the search software. See below Figure 13.

Network Settings	
Obtain IP automatically	<input type="checkbox"/>
IP Addr	192.168.0.139
Subnet Mask	255.255.255.0
Gateway	192.168.0.1
DNS Server	192.168.0.1
Http Port	80

Figure 13

#### 5.1.2 WIFI Setting

If the device is with WIFI, enter the Wireless LAN Setting, just as below Figure 14 shown, click the "Scan" button, it will show you all the wireless networks detected in the Wireless Network List column. Select one of them and tick "Using Wireless Lan", then the relevant data of the selected wireless network will be shown in the following blanks. Enter the password and click "Set", then the WIFI setting is finished.

Wireless Settings	
Wireless Network List	<div style="border: 1px solid black; padding: 2px;">           ChinaNet-TbKR[00255e1e5d08] infra WPA/WPA2-PSK            wifi[001e58f37857] infra WPA/WPA2-PSK            netview[002586697046] infra WPA/WPA2-PSK         </div> <input type="button" value="Scan"/>
Using Wireless Lan	<input checked="" type="checkbox"/>
SSID	wifi
Encryption	WPA2 Personal (AES) ▾
Share Key	8939038200

Figure 14

Note1: When the device is connected both WiFi and wired, it will firstly connect to the wired network, if it can't connect to it, then it will change and connect to WiFi. The IP address and port is the same, either wireless or wired network.

Note2: Before you start the configuration of wireless as shown above; please make sure the device is connected to the network via network cable. After settings succeed, please reboot the device and wireless function takes effect.

### 5.1.3 ADSL Setting

User could enable the ADSL Dialup according to the below Figure 15 (The ADSL provider will assign the user name and password to you when you apply for ADSL service.) Connect the device directly to the ADSL modem and it is connected to the Internet.

ADSL Settings	
Using ADSL Dialup	<input checked="" type="checkbox"/>
ADSL User	szlgview@163.gd
ADSL Password	●●●●●●

Figure 15

### 5.1.4 UPnP Setting

If you enable UPNP, once the Wireless Camera is connected into the LAN, it will communicate with the router in the LAN to do the port-forwarding automatically.

Below Figure 16, tick "Using UPNP to Map Port" and the setting are completed. You could check the UPNP succeeds or not in the interface of System Maintenance.

UPnP Settings	
Using UPnP to Map Port	<input checked="" type="checkbox"/>

Figure 16

Before using UPNP function, please make sure the router's UPNP function has been triggered. Not all the routers support UPNP perfectly. Please test if the router works well

with the equipment, if not, we would suggest you to disable this function and do the port-forwarding manually.

### 5.1.5 DDNS Setting

Please refer to the content in 4.3.

### 5.1.6 MSN Setting

MSN Config	
User	<input type="text" value="test1@hotmail.com"/>
Password	<input type="password" value="●●●●●●"/>
MSN Friends List	<input type="text" value="friend1@hotmail.com"/>
	<input type="text"/>
	<input type="text"/>
	<input type="text"/>
	<input type="text"/>
	<input type="text"/>
	<input type="text"/>
	<input type="text"/>

Figure 17

User needs to apply for a MSN account for this device first, for example: [test1@hotmail.com](mailto:test1@hotmail.com). Please put this MSN account and its password as above Figure 17. Then put your MSN account, for example: [friend1@hotmail.com](mailto:friend1@hotmail.com), into the 'MSN Friends List. Then on your [friend1@hotmail.com](mailto:friend1@hotmail.com) MSN list, you can see [test1@hotmail.com](mailto:test1@hotmail.com) is online. You just send "url?" to [test1@hotmail.com](mailto:test1@hotmail.com) and you will get the WAN ip address of this IP Camera. But please make sure [test1@hotmail.com](mailto:test1@hotmail.com) and [friend1@hotmail.com](mailto:friend1@hotmail.com) should be MSN friends before you do the settings.

## 5.2 Alarm Settings

### 5.2.1 Alarm Setting

#### 1) Alarm Detect

User can enable motion detection. If there is any motion, it will detect the motion and trigger the alarm. In motion detect sensibility, the higher the figure, the more sensitive.

As showed in Figure 18, if any external alarm detector is connected, user will be able to tick "Alarm Input Armed". If the external alarm detector is an always on switch alarm, please choose "open". If the external alarm detector is always off switch alarm, please choose "close".

Alarm Settings	
<b>Alarm Detect</b>	
Motion Detect Armed	<input checked="" type="checkbox"/> Motion Detect Sensibility 5
Alarm Input Armed	<input checked="" type="checkbox"/> <input checked="" type="radio"/> Open <input type="radio"/> Close
<b>Alarm Action</b>	
IO Linkage on Alarm	<input type="checkbox"/>
Send Mail on Alarm	<input checked="" type="checkbox"/>
Upload Image to FTP	<input type="checkbox"/>
Enable Alarm Server	<input type="checkbox"/>
<b>Scheduler</b>	
<input checked="" type="radio"/> All time <input type="radio"/> Schedule (NOTICE: set the correct 'Device Clock') Device Clock	
<input type="button" value="Submit"/> <input type="button" value="Refresh"/>	

Figure 18

## 2) Alarm Action

All kinds of alarm modes:-

- IO interface for alarm signal output: when relay is switched on, the external alarm will begin to alarm.
- Send alarm info by email.
- Send the site pictures to the FTP server, user can also set the break time between two pictures.
- Send alarm info to the alarm server.

## 3) Scheduler

Device will trigger alarm in scheduled time. User can set schedule time to be “all the time”. Before you set “Schedule”, please go to Date and Time settings to set the correct time for the item, as shown in figure 19.

Alarm Detect	
Motion Detect Armed	<input checked="" type="checkbox"/> Motion Detect Sensibility 5 <input type="button" value="v"/>
Alarm Input Armed	<input checked="" type="checkbox"/> <input checked="" type="radio"/> Open <input type="radio"/> Close
Alarm Action	
IO Linkage on Alarm	<input type="checkbox"/>
Send Mail on Alarm	<input checked="" type="checkbox"/>
Upload Image to FTP	<input type="checkbox"/>
Enable Alarm Server	<input type="checkbox"/>
Scheduler	
<input type="radio"/> All time <input checked="" type="radio"/> Schedule(NOTICE:set the correct 'Device Clock')Device Clock	
Day	0 1 2 3 4 5 6 7 8 9 10 11 12 13 14 15 16 17 18 19 20 21 22 23
Sun	<input type="checkbox"/> <input type="checkbox"/> <input type="checkbox"/> <input type="checkbox"/> <input type="checkbox"/> <input type="checkbox"/> <input type="checkbox"/> <input type="checkbox"/> <input type="checkbox"/> <input type="checkbox"/> <input type="checkbox"/> <input type="checkbox"/> <input type="checkbox"/> <input type="checkbox"/> <input type="checkbox"/> <input type="checkbox"/> <input type="checkbox"/> <input type="checkbox"/> <input type="checkbox"/> <input type="checkbox"/> <input type="checkbox"/> <input type="checkbox"/> <input type="checkbox"/> <input type="checkbox"/>
Mon	<input type="checkbox"/> <input type="checkbox"/> <input type="checkbox"/> <input type="checkbox"/> <input type="checkbox"/> <input type="checkbox"/> <input type="checkbox"/> <input type="checkbox"/> <input type="checkbox"/> <input type="checkbox"/> <input type="checkbox"/> <input type="checkbox"/> <input type="checkbox"/> <input type="checkbox"/> <input type="checkbox"/> <input type="checkbox"/> <input type="checkbox"/> <input type="checkbox"/> <input type="checkbox"/> <input type="checkbox"/> <input type="checkbox"/> <input type="checkbox"/> <input type="checkbox"/> <input type="checkbox"/>
Tue	<input type="checkbox"/> <input type="checkbox"/> <input type="checkbox"/> <input type="checkbox"/> <input type="checkbox"/> <input type="checkbox"/> <input type="checkbox"/> <input type="checkbox"/> <input type="checkbox"/> <input type="checkbox"/> <input type="checkbox"/> <input type="checkbox"/> <input type="checkbox"/> <input type="checkbox"/> <input type="checkbox"/> <input type="checkbox"/> <input type="checkbox"/> <input type="checkbox"/> <input type="checkbox"/> <input type="checkbox"/> <input type="checkbox"/> <input type="checkbox"/> <input type="checkbox"/> <input type="checkbox"/>
Wed	<input type="checkbox"/> <input type="checkbox"/> <input type="checkbox"/> <input type="checkbox"/> <input type="checkbox"/> <input type="checkbox"/> <input type="checkbox"/> <input type="checkbox"/> <input type="checkbox"/> <input type="checkbox"/> <input type="checkbox"/> <input type="checkbox"/> <input type="checkbox"/> <input type="checkbox"/> <input type="checkbox"/> <input type="checkbox"/> <input type="checkbox"/> <input type="checkbox"/> <input type="checkbox"/> <input type="checkbox"/> <input type="checkbox"/> <input type="checkbox"/> <input type="checkbox"/> <input type="checkbox"/>
Thu	<input type="checkbox"/> <input type="checkbox"/> <input type="checkbox"/> <input type="checkbox"/> <input type="checkbox"/> <input type="checkbox"/> <input type="checkbox"/> <input type="checkbox"/> <input type="checkbox"/> <input type="checkbox"/> <input type="checkbox"/> <input type="checkbox"/> <input type="checkbox"/> <input type="checkbox"/> <input type="checkbox"/> <input type="checkbox"/> <input type="checkbox"/> <input type="checkbox"/> <input type="checkbox"/> <input type="checkbox"/> <input type="checkbox"/> <input type="checkbox"/> <input type="checkbox"/> <input type="checkbox"/>
Fri	<input type="checkbox"/> <input type="checkbox"/> <input type="checkbox"/> <input type="checkbox"/> <input type="checkbox"/> <input type="checkbox"/> <input type="checkbox"/> <input type="checkbox"/> <input type="checkbox"/> <input type="checkbox"/> <input type="checkbox"/> <input type="checkbox"/> <input type="checkbox"/> <input type="checkbox"/> <input type="checkbox"/> <input type="checkbox"/> <input type="checkbox"/> <input type="checkbox"/> <input type="checkbox"/> <input type="checkbox"/> <input type="checkbox"/> <input type="checkbox"/> <input type="checkbox"/> <input type="checkbox"/>
Sat	<input type="checkbox"/> <input type="checkbox"/> <input type="checkbox"/> <input type="checkbox"/> <input type="checkbox"/> <input type="checkbox"/> <input type="checkbox"/> <input type="checkbox"/> <input type="checkbox"/> <input type="checkbox"/> <input type="checkbox"/> <input type="checkbox"/> <input type="checkbox"/> <input type="checkbox"/> <input type="checkbox"/> <input type="checkbox"/> <input type="checkbox"/> <input type="checkbox"/> <input type="checkbox"/> <input type="checkbox"/> <input type="checkbox"/> <input type="checkbox"/> <input type="checkbox"/> <input type="checkbox"/>
<input type="button" value="Submit"/> <input type="button" value="Refresh"/>	

Figure 19

## 5.2.2 Mail Service Setting

eMail Settings	
Sender	sender@sohu.com
Receiver 1	receiver@sohu.com
Receiver 2	
Receiver 3	
Receiver 4	
SMTP Server	smtp.sohu.com
SMTP Port	25
Transport Layer Security Protocol	None <input type="button" value="v"/>
Gmail only support TLS at 465 port and STARTTLS at 25/587 port.	
Need Authentication	<input checked="" type="checkbox"/>
SMTP User	sender
SMTP Password	••••••••
<input type="button" value="Test"/>	Please set at first, and then test.
Report Internet IP by Mail	<input type="checkbox"/>

Figure 20



The device will send alarm email to you. You only need to fill out the blanks with your email address as shown in Figure 20. After the setting, please click save and test to check if it works properly. If it is properly set, user can tick to enable “Report Internet IP by mail”. After every restart, the device will send its Internet IP address to user’s email address.

### 5.2.3 FTP Service Setting

Ftp Settings	
FTP Server	192.168.0.56
FTP Port	21
FTP User	test
FTP Password	•••••
FTP Upload Folder	/test
FTP Mode	PORT ▾
<input type="button" value="Test"/>	Please set at first, and then test.
Upload Image Periodically	<input type="checkbox"/>

Figure 21

When alarming, device will snap and send the image to FTP server, please make sure the FTP setting is correct. Above Figure 21 of FTP setting for your reference, after the setting is finished, click “Test” to test your settings are correct or not.

After correct setting FTP server, you can use “upload Image Periodically” function. Even no alarm, device can also send the snap image to FTP periodically.

In order to use FTP function, user should apply username and password on the FTP server first. And please apply some storage, and the authority to write and create sub-category into it.

### 5.2.4 Alarm Server

Alarm server	
Server Address:	192.168.0.78
Server Port:	1000
User Name:	test
Password:	•••••

Figure 22

Please confirm if you have connected to alarm server. The alarm message format as follow:

```
GET /api/alarm.asp?
  username=username&
```

```

userpwd=password&
rea=alarm type (1=Motion Detection, 2 =Alarm from Alarm in port)&
io=0

```

Alarm server needs developing by user. User can extend other functions on this server, like SMS, MMS alarm, and mobile phone etc.

## 5.3 Advanced

### 5.3.1 User Setting

There are three levels of authority; they are Administrator/Operator/Visitor. Administrator have the highest authority, it can do any change to the settings. Operator account only can operate the IP camera, can't do changes to the settings. Visitor account only can watch the video, can't do any operation to the IP camera. **By default, the administrator's user name is admin, password: 123456.**

Users Settings		
User	Password	Group
admin	••••••	Administrator ▼
user	••••	Operator ▼
guest	•••••	Visitor ▼

Figure 23

### 5.3.2 Multi Device Setting

Multi-Device Settings	
Device List in Lan	anonymous(192.168.0.247) 002alc(192.168.0.67) 002abyc(192.168.0.239) 002aqvc(192.168.0.241)
	<input type="button" value="Refresh"/>
The 1st Device	This Device
The 2nd Device	None
The 3rd Device	None
The 4th Device	None
The 5th Device	None
The 6th Device	None
The 7th Device	None
The 8th Device	None
The 9th Device	None
attention: If you want to access the device from internet, be sure the host and port that you set can be accessed from internet.	
<input type="button" value="Submit"/> <input type="button" value="Refresh"/>	

Figure 24

As Figure 24, User can maximum add 9 devices to view the device simultaneously. Click refresh button to check the device in the LAN. When click the device, will popup setting dialogue box and input the device info, as figure 25 and click save. After that, must click submit button to save.

The 2nd Device	None
Alias	<input type="text" value="002alcl"/>
Host	<input type="text" value="192.168.0.67"/>
Http Port	<input type="text" value="80"/>
User	<input type="text" value="admin"/>
Password	<input type="password" value="••••••"/>
<input type="button" value="Save"/> <input type="button" value="Remove"/>	

Figure 25

### 5.3.3 Other settings

You can choose open or close indicator LED. If set PTZ center on start 'Yes', when start device, Pan/Tilt will move to center and then stop. You can also set the Horizon patrol rounds and vertical patrol rounds, when you click patrol on the 'view' interface, it will round according to your setting rounds. You can also set PTZ rate, 0 means fastest.

Other Settings	
Status LED Mode	<input type="text" value="Open Indicator LED"/> ▾
<b>PTZ settings</b>	
PTZ Center on Start	<input type="text" value="No"/> ▾
Horizon Patrol Rounds	<input type="text" value="1"/> ▾ (NOTE: 0 means infinity)
Vertical Patrol Rounds	<input type="text" value="1"/> ▾ (NOTE: 0 means infinity)
Manual PTZ Rate	<input type="text" value="0"/> ▾
Auto Horizon Rate	<input type="text" value="5"/> ▾
Auto Vertical Rate	<input type="text" value="5"/> ▾
<b>Path Set</b>	
Record Path	<input type="text" value="C:\Documents and Settings\All Users\Documents"/> <input type="button" value="Browse.."/>

Figure 26

## 5.4 Maintain

### 5.4.1 Device Information

Device Info	
Device ID	002aaai
Device Firmware Version	21.37.2.37
Device Embeded Web UI Version	0.0.4.18
MAC	00:01:02:03:02:03
Alarm Status	None
Third Party DDNS Status	3322 Succeed <a href="http://robbicam1.3322.org:10540">http://robbicam1.3322.org:10540</a>
UPnP Status	No Action
MSN Status	No Action

Figure 27

### 5.4.2 Time Setting

If the device is connected to the Internet, you enable the NTP server to correct the time and select the right time zone. Or you should use the PC's time to correct its time.

Date & Time Settings	
Device Clock Time	2010 - 3 - 29 20:08:20
Device Clock Timezone	(GMT +08:00) Beijing, Singapore, Taipei <input type="button" value="v"/>
Sync with NTP Server	<input checked="" type="checkbox"/>
Ntp Server	time.nist.gov <input type="button" value="v"/>
Sync with PC Time	<input type="checkbox"/>

Figure 28

### 5.4.3 Firmware upgrade

The device runs 2 kinds of programmer, one is system firmware, the other is application firmware. They could be upgraded separately.

Upgrade Firmware	
Upgrade Device Firmware	<input type="text"/> <input type="button" value="Browser..."/> <input type="button" value="Submit"/>
Upgrade Device Embeded Web UI	<input type="text"/> <input type="button" value="Browser..."/> <input type="button" value="Submit"/>

Figure 29

### 5.4.4 Restore Factory Default

Click "Restore Factory Default", it will pop up a dialogue to confirm if you really want to restore the factory default. After confirmation, the system will restore the factory default and reboot.

### 5.4.5 User browsing Log

After enter the log interface, you could view who and when the device is visited.

Log				
Mon, 2010-03-29 19:05:20	admin	192.168.0.175	access	
Mon, 2010-03-29 19:43:33	user	192.168.0.175	access	
Mon, 2010-03-29 19:47:51	user	192.168.0.175	access	
Mon, 2010-03-29 19:49:02	guest	192.168.0.175	access	
Mon, 2010-03-29 19:57:40	admin	192.168.0.175	access	

Figure 30

## 6 Centralization Control

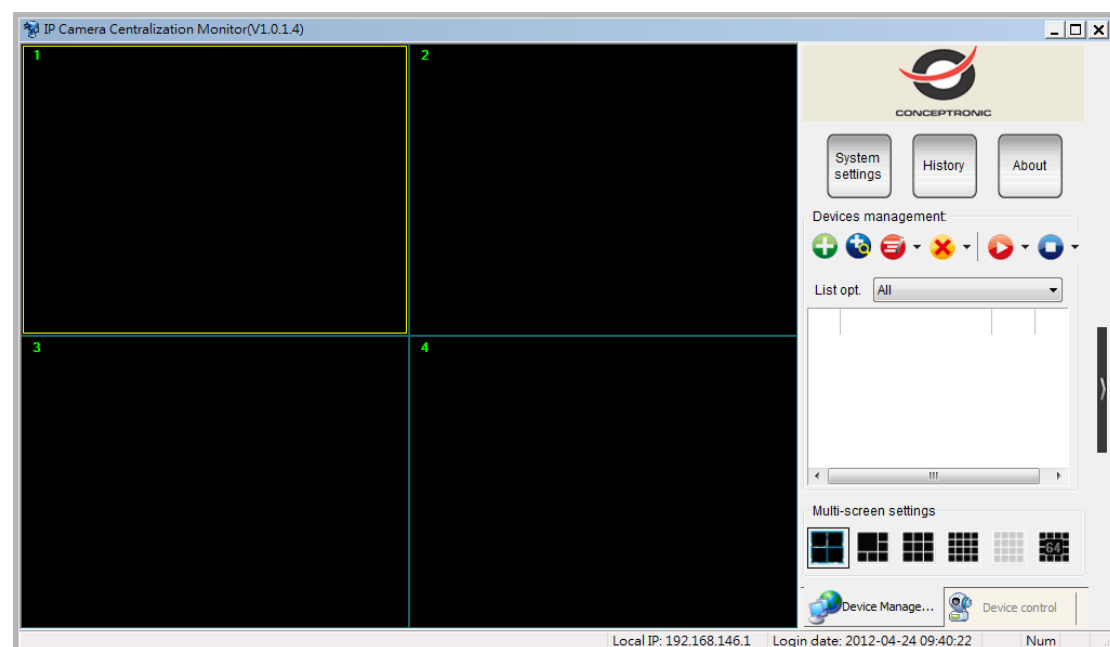

Figure 31

IPCMonitor is a free software offered by factory, several devices on LAN and WAN can be browsed at the same time. The software also supports snap, video record, alarm and so on. The below Figure 31 is the interface.

For more information, pls. refer to the <<IPCMonitor User Manual>> in CD.

## 7 FAQ

### 1) Unmatched power adapter will damage the equipment or power adapter

When plug in the power adapter, please check carefully the voltage, it should be 5V adapter for this equipment.

## 2) Slow browser speed

This equipment adopts MJPEG compression format, it needs large network bandwidth, the narrow bandwidth will affect the browse speed. The typical bandwidth uses situation as below:

640x480@10fps : 4.0 Megabits ~ 5.0 Megabits

320x240@30fps : 1.2 Megabits ~ 1.6 Megabits

## 3) Color difference

The default is infrared lens, when visit outdoor or strong infrared light scenes, there are color differences, the color is not accordance to the real scenes. User can change it to color lens to solve this problem, but color lens can only use under the daylight situation.

## 4) Can't find equipment via search software after connect to LAN

Make sure the equipment and PC is in the same LAN; if install firewall software, please close it and try again.

## 5) Can find equipment via search software, but can't visit

If the IP address of IP camera and PC is not in the same Network Segment, you should change them on the same Network Segment before visit. Network Segment is the first three number of IP address. If the IP address of PC is 192.168.0.100, so it can only visit the equipment which IP address is between 192.168.0.1~192.168.0.255.

## 6) Can visit via public IP address, but can't visit via manufacturer's domain name

Make sure the DNS setting is same as your PC, as below Figure 33, in the search tool, the DNS 1 and DNS 2 on both side should be same.

The screenshot displays a network configuration window with two main sections: 'Local PC information' and 'Device information'.

**Local PC information:**

- Network adapter: Realtek RTL8139/810x Far
- IP address: 192.168.0.175
- Subnet mask: 255.255.255.0
- Gateway: 192.168.0.1
- DNS1: 192.168.0.1
- DNS2: (empty)

**Device information:**

- Device name: 002alcn
- Sys. FirmwareVer: 21.37.2.37
- App. FirmwareVer: 0.0.4.18
- IP config:  Set IP automatically
- IP address(I): 192 . 168 . 0 . 78
- Subnet mask(U): 255 . 255 . 255 . 0
- Gateway(G): 192 . 168 . 0 . 1
- DNS1(D): 192 . 168 . 0 . 1

At the bottom left, there is a 'Device list' section showing '1 pcs'.

Figure 32